

*OIL COOLER - BOL - Remote Mount*

# Installation Guide



## IMPORTANT SAFETY NOTICE

Read, understand and observe all procedure and safety instructions before installing the MEI Oil Cooler. Observe all safety information and note specific safety requirements as explained by procedures called out in this manual. Failure to follow these instructions could result in serious personal injury or death.



Save this user's guide for future reference.

INSTALLATION LOCATION: \_\_\_\_\_

INSTALLATION DATE: \_\_\_\_\_

OIL COOLER SERIAL NUMBER: \_\_\_\_\_

If you have questions on:  
**SAFETY - OPERATIONS - APPLICATIONS**

CALL 1-800-944-1811



# TABLE OF CONTENTS

<b>1</b>	<b>Safe Installation Practices.....</b>	<b>5</b>
	A. Work Area Safety .....	5
	B. Hydraulic Systems .....	5
<b>2</b>	<b>Oil Cooling Principles.....</b>	<b>6</b>
	A. Introduction to Oil Cooling.....	6
	B. Operational Advantages to Oil Cooling .....	6
<b>3</b>	<b>Preparing For Installation .....</b>	<b>7</b>
	A. Qualified Operator .....	7
	B. Tool / Supply Requirements .....	7
	C. Unpacking the Oil Cooler .....	7
<b>4</b>	<b>Installation Instructions .....</b>	<b>8–15</b>
	A. Determining the System Location.....	8
	B. Preparation and Drilling of Power Unit for Direct Mount.....	9
	C. Mount the Thermostat and Sensor Bulb .....	9
	D. Attach Mounting Bracket.....	10
	E. Mount Heat Exchanger	
	E-1) Direct Mount Heat Exchanger .....	11
	E-2) Remote Mount Heat Exchanger.....	12–13
	F. Hydraulic Intake and Return Hose Connections .....	13–14
	G. Electrical Connections .....	15
<b>5</b>	<b>System Operation And Maintenance .....</b>	<b>16</b>
	A. Set Thermostat .....	16
	B. Maintenance.....	16
<b>6</b>	<b>Troubleshooting .....</b>	<b>18–19</b>
	A. Thermostat .....	18
	B. Heat Exchanger.....	18
	C. Oil Filter.....	19
	D. Connections .....	19
	E. Pump / Motor Assembly.....	19
<b>7</b>	<b>Appendices.....</b>	<b>20–22</b>
	Appendix A-1, Parts List .....	20
	Appendix A-2, Parts Diagram .....	21
	Appendix B, Warranty.....	22



---

MEI - TOTAL ELEVATOR SOLUTIONS  
**OIL COOLER- BOL - P/N 20856**

# SAFE INSTALLATION PRACTICES

Read, understand and observe all procedure and safety instructions before installing the MEI Oil Cooler. Observe all safety information and note specific safety requirements as explained by procedures called out in this manual. Failure to follow these instructions could result in serious personal injury or death.

All tools, materials and equipment manufactured and supplied by MEI - Total Elevator Solutions (MEI) are designed to be used and installed by qualified and trained personnel only. MEI will not be held liable for any injury or damage to either people or property resulting from the misuse of MEI equipment.

## A. Work Area Safety

1. Wear personal protective equipment: hard hat, safety glasses, safety shoes, and leather work gloves.
2. The safe installation of this equipment requires that the operators be on stable footing.
3. Stay clear of pressurized hydraulic lines and electrical lines.
4. Use the oil cooler for its intended purpose only.

## B. Hydraulic Systems

Escaping fluids under pressure can penetrate the skin and cause serious personal injury. Observe the following precautions to avoid hydraulic hazards:

1. Tighten all connections before turning on power. Lockout when connecting or disconnecting hoses and when servicing the unit.
2. Check for leaks with a piece of cardboard. Do not use your hands!
3. Do not exceed working pressure of hydraulic hoses.
4. Visually inspect hoses regularly and replace if damaged.



**SAVE THESE INSTRUCTIONS**

# OIL COOLING PRINCIPLES

## 2

### A. Introduction to Oil Cooling

When the oil in your system becomes too hot, elevator performance degrades and thermal cutouts cause shutdown. Furthermore, high oil temperatures cause seals and other elevator components to deteriorate prematurely, leading to more frequent repairs and downtime. The MEI Oil Cooler addresses high oil temperature problems by continuously monitoring the oil. When the oil temperature reaches a predetermined threshold, the system activates and cools the oil until it reaches a preset value. The system operates independently of your elevator system, keeping the oil at lower average temperatures. The resulting improvement in elevator performance, reliability, and component life can have a significant effect on elevator traffic handling and customer satisfaction.

### B. Operational Advantages to Oil Cooling:

The oil cooler system is connected to the existing hydraulic power unit. When oil temperature in the reservoir reaches a preset limit (usually between 110° F and 115° F) the oil cooler begins to circulate oil from the reservoir through its radiator. This reduces oil temperature by as much as 40° F depending on site conditions (**figure 1**). As an added feature, the oil cooler also **filters the oil** as it works, resulting in long-term benefits for system components.

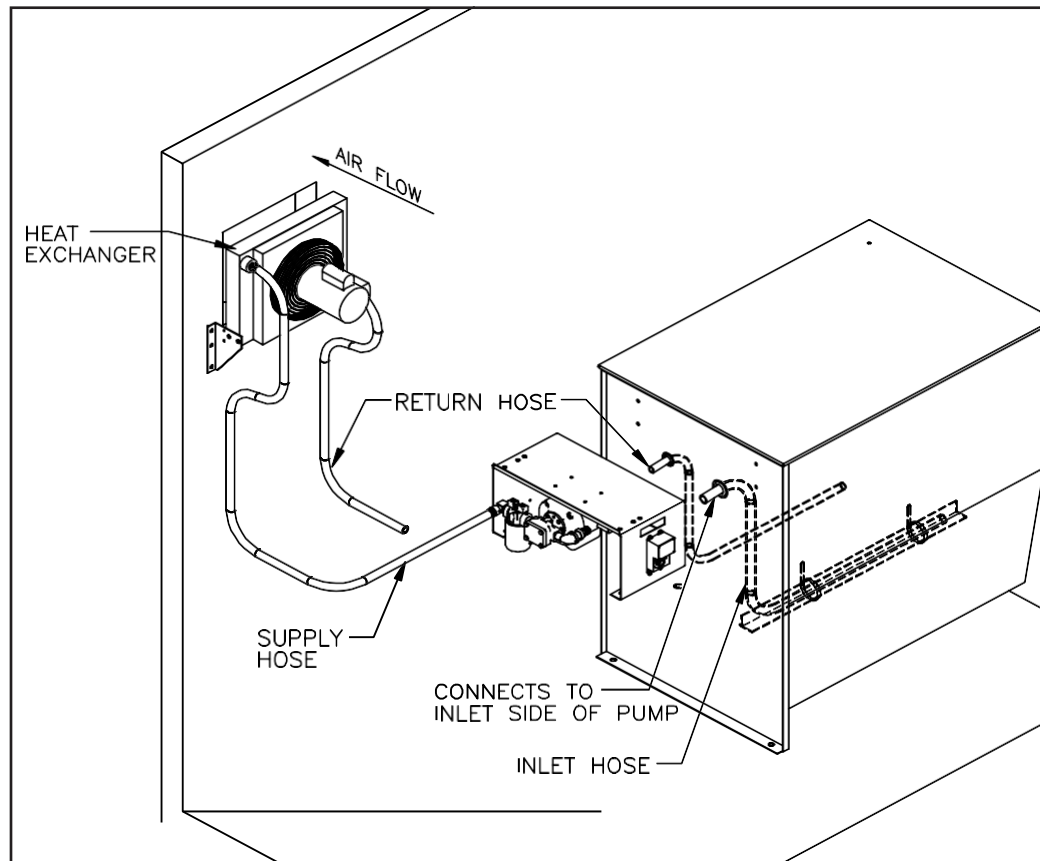

**Fig. 1: oil flow diagram from reservoir, to cooler, back to reservoir.**

## A. Qualified Installer

Installation of the oil cooler should be carried out by suitably trained, qualified, and certified personnel only. New personnel or personnel in training should be working under the constant supervision of a qualified person. Personnel installing the oil cooler should have sufficiently studied the operating manual.

## B. Tool / Supply Requirements

Oil cooler installation will require the use of the following tools / hardware. Check to see that you have them available before beginning:

- 9/16-in. wrench
- 7/16-in. wrench
- adjustable wrench up to 1 1/8-in.
- 1 1/8-in. open end wrench
- wire strippers
- wire nuts (3)
- 2-in. hole knockout tool
- 7/16-in. drill bit
- Separate electrical circuit of 115VAC or 208-230VAC single phase power supply
- lengths of #12 AWG for fan motor connection
- lengths of conduit for wall mount wiring

For remote mounting of a distance further than the supplied hose will allow, your installation may also require these additional supplies not included with the MEI Oil Cooler system:

- 1-in. iron or copper pipe
- fittings, clamps and supports for remote oil lines
- lengths of #12 AWG for fan motor connection
- lengths of conduit for remote wiring
- Cold Weather Kit #19919

## C. Unpacking the Oil Cooler

Each MEI Oil Cooler package comes complete with the following assemblies:  
Refer to appendix A-1 for a complete parts breakdown.

- Oil Cooler Assembly
- Parts Package to include:
  - (4) #10-24 x 1/2" Phillips Pan Head Bolt
  - (4) #10-24 Lock Nut
  - (6) Cable Ties
  - (1) Bulkhead Intake Hose Fitting
  - (1) Sealing Locknut
  - (1) 9/32" I.D. Grommet
  - (2) 3/8"-16 x 1" Carriage Bolts
  - (2) 3/8"-16 Hex Nuts
  - (2) 3/8" Lock Washers
  - (4) 3/8"-16 x 1" Hex Head Bolts
  - (4) 3/8"-16 Lock Nut
  - (4) 3/8" Flat Washer
  - (1) 1 1/2" T-Bar Hose Clamp
- Remove Heat Exchanger from Mounting Bracket

# INSTALLATION INSTRUCTIONS

## 4

### A. Determining the System Location

The mounting bracket and oil pump motor assembly attach directly to the elevator system's hydraulic oil reservoir. Choose location based on space requirements of oil cooler (figure 2) and general room layout.

The heat exchanger mounts *directly* on the wall (figure 3) except where the following conditions are present.

- Insufficient space
- Insufficient venting

A remote mounting location is then necessary (figure 4). See Section E-2 for details.

**NOTE:** If your Heat Exchanger will be installed where the temperature gets below 50° F, contact MEI Product Support at 507-407-6550 to discuss our Cold Weather Kit, #19919.

**NOTE:** Machine room temperature and/or the heat exchanger room temperature must be between 50°–90° F. for maximum system performance, the oil cooler will transfer up to 21,600 BTU's of heat out of the oil into the area it is located.

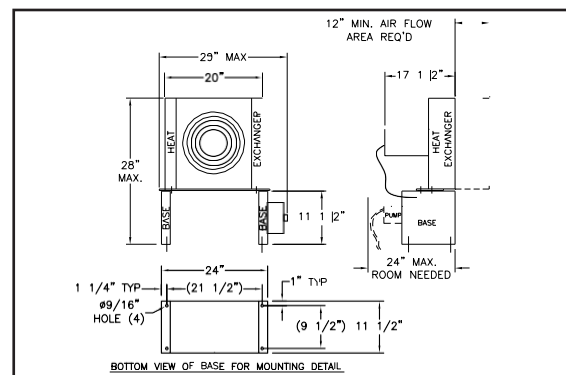

**Fig. 2: Oil cooler overall dimensions, wt. 150 lbs.**

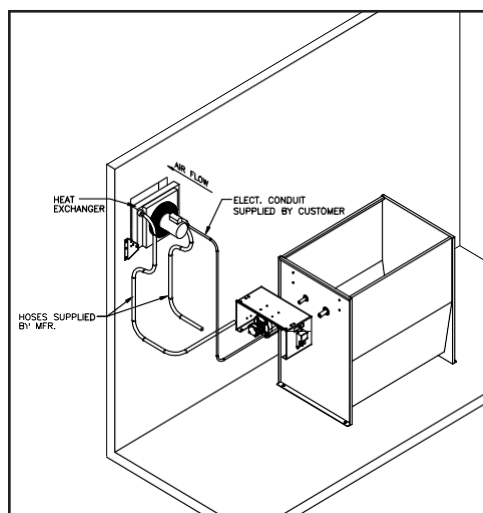

**Fig. 3: Typical installation with wall mount of heat exchanger only.**

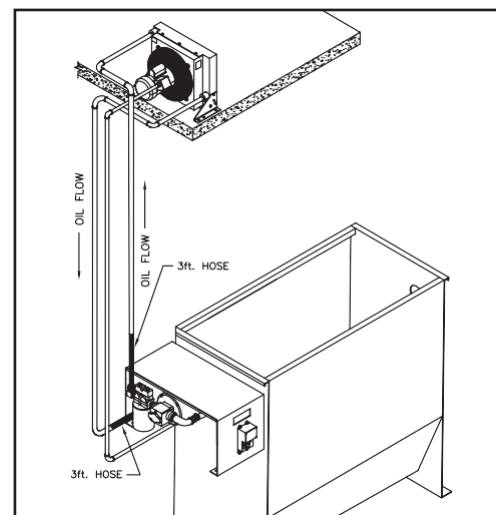

**Fig. 4: Typical installation with (remote mount) of heat exchanger only.**

## B. Preparation and Drilling of Power Unit Holes for Mounting Bracket

Locate hose, thermostat and mounting bracket holes with paper template (**attachment 1**).

**NOTE:** Use optional uni-strut mounting for additional structural supports (**figure 8**) if oil level in tank will not allow drilling per template.

Position the paper mounting template that comes with the cooler on the side of the tank (reservoir) where the cooler will be fastened (**figure 5**). This template provides locations for the intake hose (2-3/8-in.) and return hose (2-in.), one 7/16-in. thermostat sensor bulb hole and four 7/16-in. mounting holes. Position the template so that the top edge of the paper is flush with the top edge of the tank wall. This will locate the mounting bracket approximately 1/2-in. below the top of the tank providing clearance for the tank cover. Tape the template in place and mark the hole centers with a center punch.

**!CAUTION: Avoid leaking oil! Before drilling, make sure holes are located at least 6-in. above the maximum oil level in tank with the car at its lowest possible point in the hoistway.**



Drill the four mounting holes and the thermostat sensor bulb hole and knockout the hose holes in the tank. Take precautions to prevent any metal particles from entering the oil.

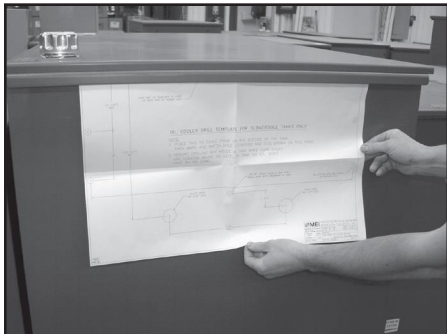

**Fig. 5:** Use template (supplied) for placement of mounting holes.

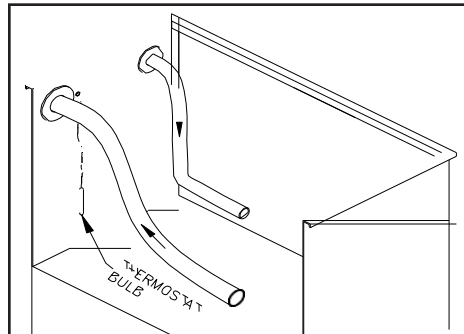

**Fig. 6:** Sensor bulb placement.

## C. Mount Thermostat and Sensor Bulb

You may choose to mount the thermostat on the right or left side of the oil cooler mounting bracket. Attach it using the four #10-24 x 1/2" bolts and locknuts (provided). Set the thermostat, recommended setting is between 110–115°F, conditions may vary.

As per template instructions above the thermostat sensor bulb is routed through a 7/16-in. hole and grommet in the reservoir tank (**figure 6**). Locate the 9/32-in. I.D. Grommet and install. Do not allow Sensor Bulb to hang loosely in tank. Secure with suitable cable tie or other means.

# INSTALLATION INSTRUCTIONS

## 4

### D. Attach Mounting Bracket

Install the mounting bracket by inserting the two 3/8-in. carriage bolts, washers, and locknuts (provided) in the upper mounting holes on the tank with the washers and nuts inside the tank (figures 7a & 7b).

Leave these nuts loose. Lift the mounting bracket into place and position the two key slot holes over the carriage bolts. Pass two 3/8-in. bolts through the lower mounting holes in the bracket through the tank and fasten with washers and locknuts. Tighten all fasteners.

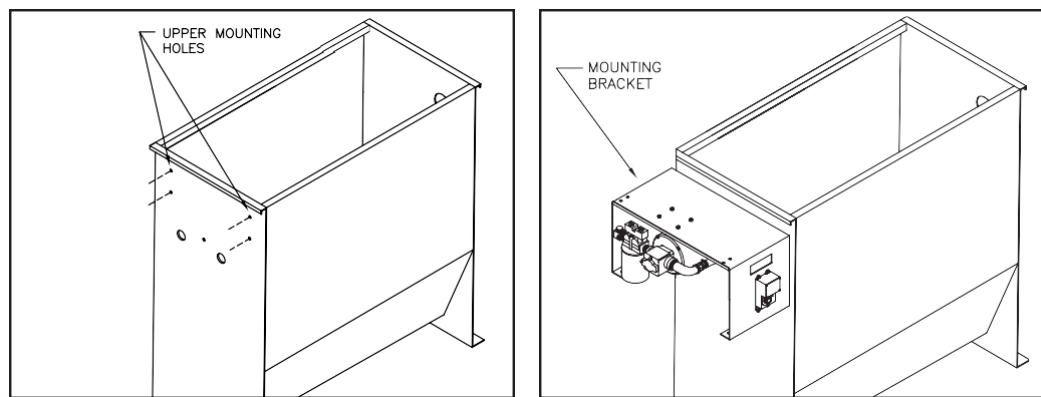

Fig. 7a & 7b: Installation of mounting bracket directly to power units only.

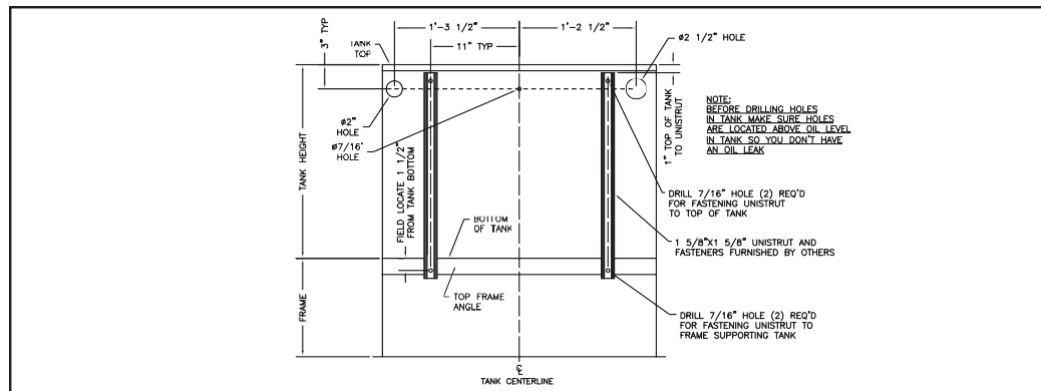

Fig. 8: Optional mounting method using uni-strut.



Install Uni-strut per (figure 8). Install oil cooler mounting bracket onto the uni-strut using the (4) 3/8-in. hex head bolts, washers and nuts provided. Rotate 90° elbow to the necessary position making sure not to loosen fitting.

**!CAUTION: Avoid leaking oil! Before drilling, make sure holes are located at least 6 in. above the maximum oil level in tank with the car at its lowest possible point in the hoistway.**

## E-1. Wall/Duct Mount Heat Exchanger

**SKIP TO SECTION E-2 IF EXCHANGER WILL BE MOUNTED REMOTELY.**

If the heat exchanger will be mounted to the wall, you must rotate heat exchanger mounting brackets 90° as shown in (figure 9). Determine wall type and secure the heat exchanger appropriately.

**IMPORTANT! Only 50-ft. of hose is supplied for making supply and return hoses to tank.**

**PROCEED TO SECTION F FOR HYDRAULIC HOSE CONNECTIONS.**

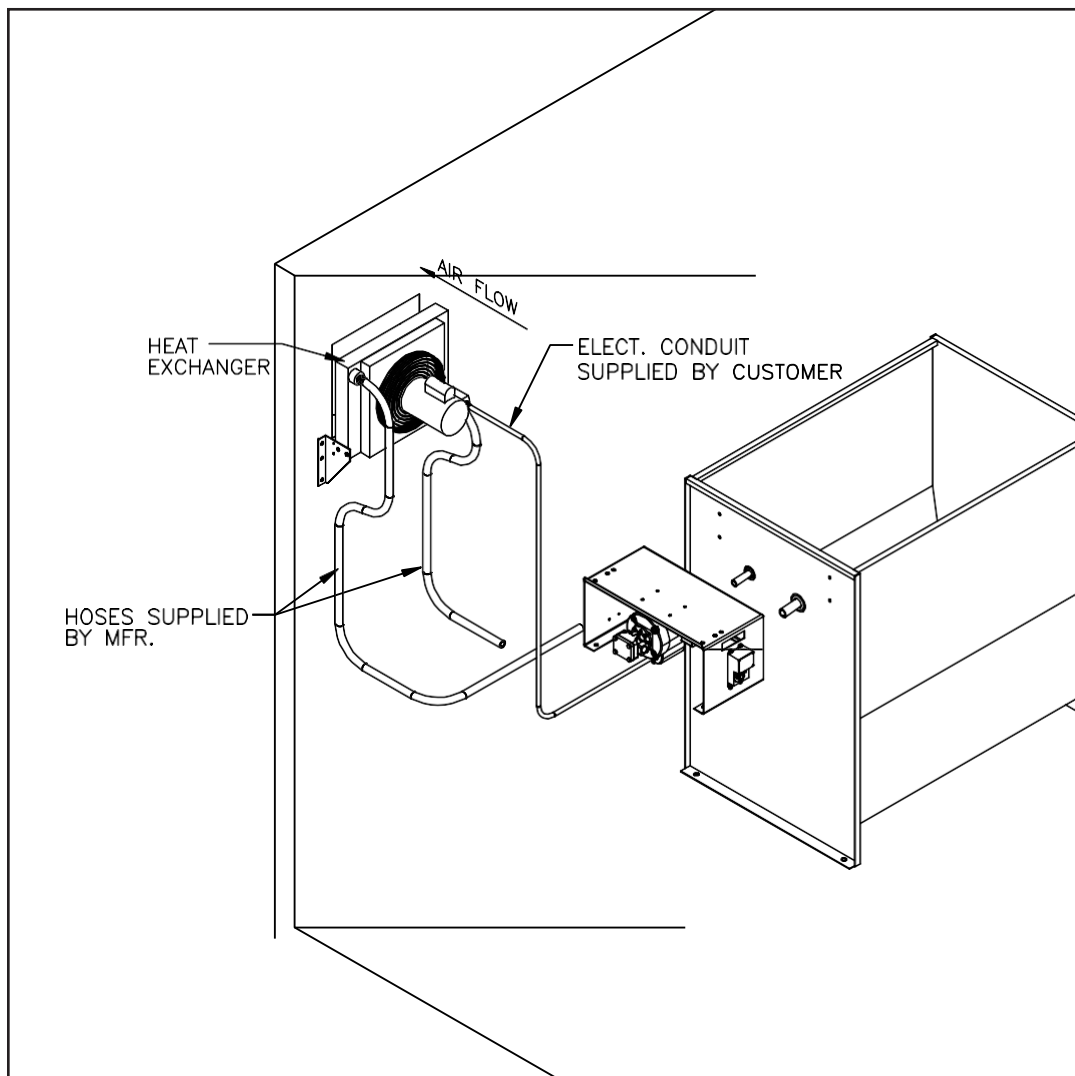

**Fig. 9: Heat exchanger shown on mounting bracket (wall mount).**

# INSTALLATION INSTRUCTIONS

## 4

### E-2. Remote Mount Heat Exchanger

**SKIP TO SECTION F IF EXCHANGER WAS WALL MOUNTED.**

If heat exchanger will be mounted remotely, system performance may be diminished if mounted too far away (**figure 10**). Use the formula below to determine optimum placement (see also **table 1**).

**!CAUTION: Heat exchanger needs to be mounted in an enclosed area that can maintain a temperature between 50°–90° F.**

$$\frac{\text{Horizontal Run (ft.)}}{10} + \frac{\text{Vertical Run (ft.)}}{5} \leq 11$$

**Example 1:** Pipe run needed is 40 feet horizontal and 35 feet vertical.

$$\frac{40 \text{ ft.}}{10} + \frac{35 \text{ ft.}}{5} = 4 + 7$$

Since 4 + 7 does not exceed 11, this pipe run is acceptable.

**Example 2:** Pipe run needed is 80 feet horizontal and 25 feet vertical.

$$\frac{80 \text{ ft.}}{10} + \frac{25 \text{ ft.}}{5} = 8 + 5$$

Since 8 + 5 does exceed 11, this pipe run is not acceptable and must be shortened.

For a given Horizontal run (ft.)	0	10	20	30	40	50	60	70	80	90	100	110
Max allowable Vertical run (ft.)	55	50	45	40	35	30	25	20	15	10	5	0

**Table 1. Minimize elbows along the run. These ratios assume a maximum of five 90° elbows.**

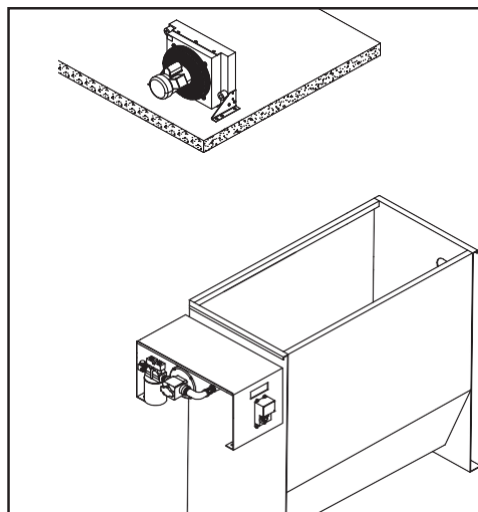

**Fig. 10: Typical remote mount location.**

- 1) Attach the heat exchanger securely to the mounting surface (floor or wall in horizontal or vertical direction) with concrete wedge anchor bolts.



# INSTALLATION INSTRUCTIONS

4

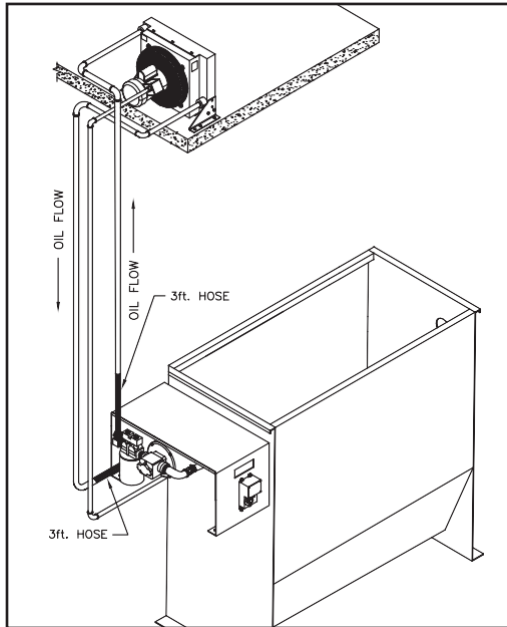

**Fig. 11: Typical piping for remote mount heat exchanger.**

3) Pipe the remote section of the oil cooler (**figure 11**) with iron or copper pipe.

**!CAUTION: Maintain safe oilflow pressure; use 1-in. iron or copper piping, rated for a minimum of 75 psi for remote exchanger connections.**

4) Make (2) 3-ft. hoses from supplied hose and fittings. Connect to return bulkhead fitting and discharge side of filter. Complete connections to iron/copper pipe.

5) Run electrical conduit between components and make electrical connections to the fan motor (**figure 11**).



**!DANGER: Electrical equipment is hazardous. Train personnel to use basic safety precautions. Misuse can result in serious personal injury or death.**



**ALL INSTALLATIONS CONTINUE BELOW.**

## F. Hydraulic Intake and Return Hose Connections

1) Locate the 96-in. intake hose and the intake hose bulkhead fitting with sealing locknut. Install intake fitting and route the intake hose through the intake fitting (**detail 11a**) into the tank. The **intake hose** hangs inside the reservoir and should be fastened with cable ties so it remains below the oil level when car is at top landing. Connect hose to pump using supplied hose clamp. Tighten compression nut on intake hose fitting so that hose no longer slides freely.

2) Locate 35-in. return hose with 90° bulkhead fitting. Connect this hose through the reservoir wall so that the **return hose** hangs **inside the reservoir** (**detail 11b**). Requires disassembly of bulkhead fitting.

3) Trim the return hose to hang approximately 4-in. above reservoir bottom (**figure 12a**).

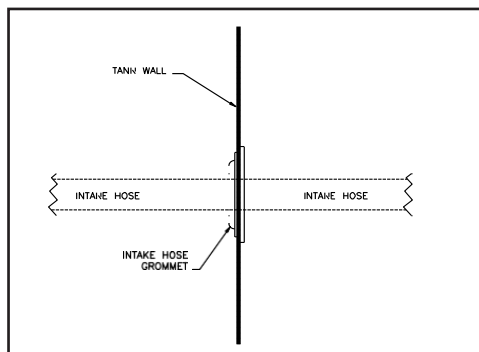

**Detail 11a: Intake hose connection.**

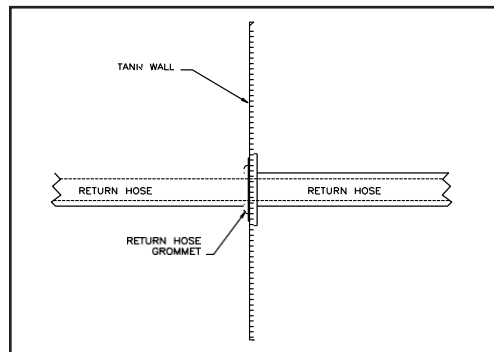

**Detail 11b: Return hose connection.**

# INSTALLATION INSTRUCTIONS

## 4

For best results, keep the open ends of intake and return hoses as far away from each other as possible (figures 12a & 12b).

**Make sure that the open end of the intake hose will remain below the surface of the oil when the car is at the top landing. This hose should be secured with cable ties and trimmed to fit the tank as needed.**

- 4) Determine lengths for supply and return hoses from heat exchanger to the tank. Make hoses from 50-ft. supplied hose and fittings in the fastener pack. Route hoses and secure using clips supplied.
- 5) Tighten all hose connections and bulkhead fitting.

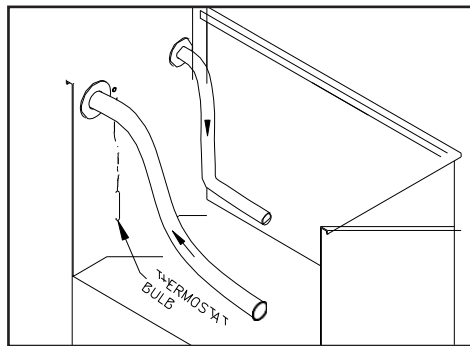

Fig. 12a: Intake (L) and return (R) hoses.

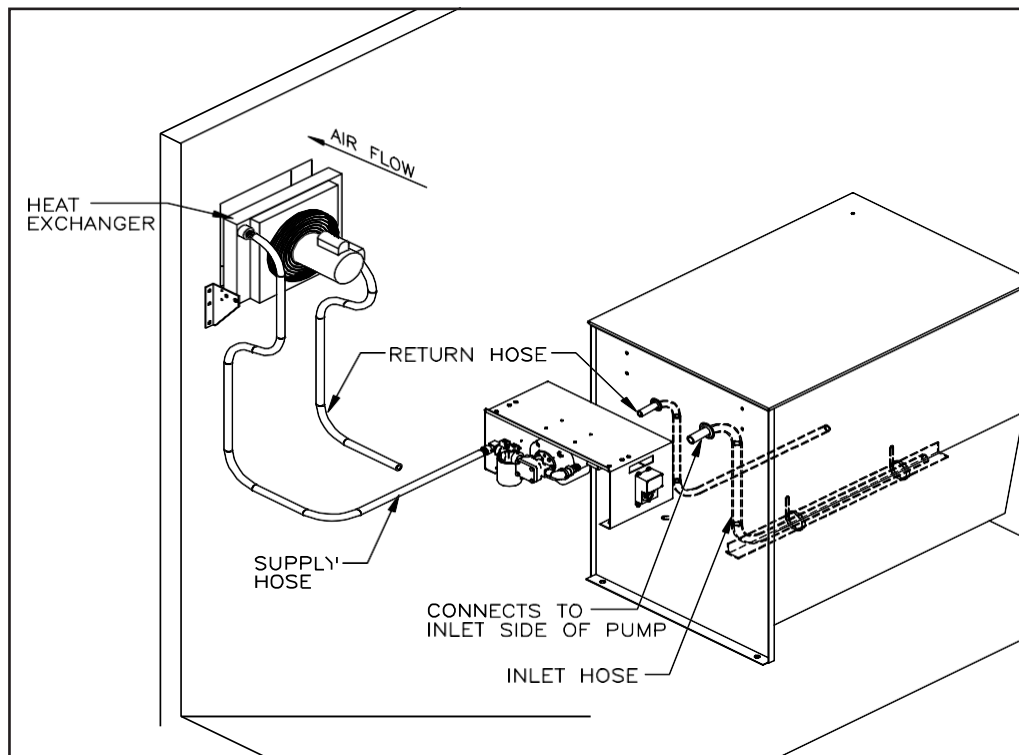

Fig. 12b: Oil flow through intake and return hoses.

### G. Electrical Connections

Make all the electrical connections as shown in the wiring diagram (figure 13). The oil cooler should be electrically connected to a separate 115 VAC or 208-230 VAC single phase 20-amp circuit with breaker. The power supply must have a means of locking it out for maintenance and repair purposes.

**!DANGER: Electrical equipment is hazardous. Train personnel to use basic safety precautions. Misuse can result in serious personal injury or death.**



Note: Refer to motor name plate or junction box cover for motor lead connection of low or high voltage.

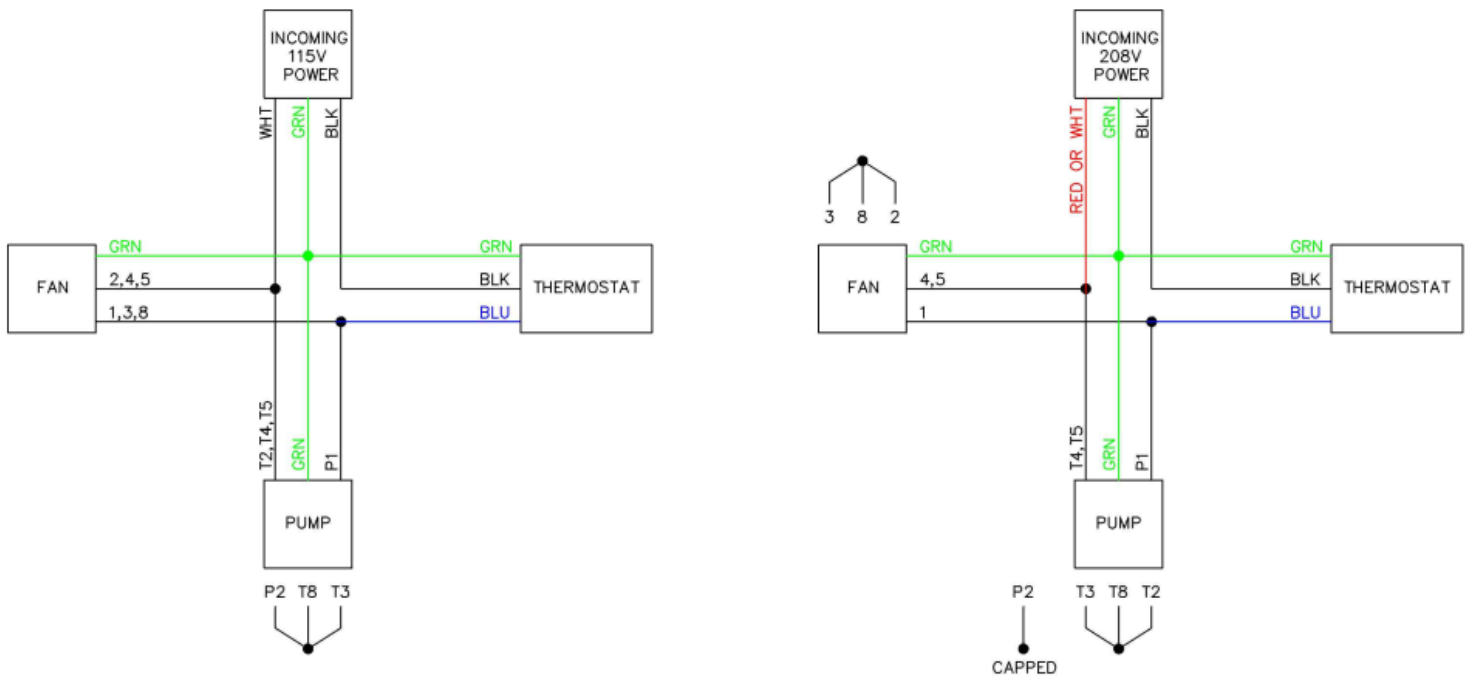

Fig. 13: Wiring diagram.

## SYSTEM OPERATION & MAINTENANCE

---

# 5

### **A. Set Thermostat**

Set the thermostat, recommended setting is between 110–115° F, conditions may vary.

### **B. Maintenance**

Oil Filter: Replace when the GREEN indicator plug turns RED (unit must be running) or every year which ever comes first.

Hoses: Visually inspect for any kinks or leaks. Replace as required.

Heat Transfer Coils: Visually inspect for contaminants. Brush or blow clean as required.



## 6

### A. Thermostat

Symptom	Possible Cause	Corrective Action
Unit does not turn on.	1. Wiring connections loose.	1. Check and tighten.
	2. Thermostat defective.	2. Replace thermostat.
	3. No power to unit.	3. Check wiring connections.
Unit does not turn off.	1. Thermostat defective.	1. Replace thermostat.
	2. Heat exchanger is in too warm of a location.	2. Review “System Location” on page 8.

### B. Heat Exchanger / Motor Assembly

Symptom	Possible Cause	Corrective Action
Not cooling adequately.	1. Not enough air flow.	1. Clean coils with soft brush if dirty.
	2. Heat exchanger is in too warm of a location.	2. Review “System Location” on page 8.
	3. Unit is undersized.	3. Review “System Location” on page 8.
	4. Sludge on internal tube surfaces.	4. Replace Heat Exchanger.
	5. Motor not working.	5. Check wiring connections.
	6. Remote mount is too far away.	6. Calculate distance using formulas and ratios on page 12.
	7. Oil filter is dirty or clogged.	7. Replace filter.
	8. Heat exchanger fan unable to overcome back pressure from duct.	8. Need positive air pressure in machine room, or add assist fan in duct.

## C. Oil Filter

Symptom	Possible Cause	Corrective Action
Leaking oil.	1. Not tightened properly.	1. Remove and apply a film of oil on filter gasket before tightening.
Visual indicator is in the Red zone (must be running).	1. Oil filter is dirty or clogged.	1. Replace filter.
	2. Oil temperature is too low.	2. Run elevator to warm the oil up.

## D. Connections, Hydraulic Oil

Symptom	Possible Cause	Corrective Action
Leaking at connections.	1. Not tight.	1. Tighten carefully.
	2. No thread sealant.	2. Remove pipe, apply thread sealant and reinstall.

## E. Pump / Motor Assembly

Symptom	Possible Cause	Corrective Action
High noise level.	1. Inlet line restriction.	1. Remove Restriction
	2. Sharp bend in hose.	2. Re-route to prevent bend.
	3. Pump/motor assembly mounted remotely.	3. Mount on oil reservoir
	4. Internal fan on pump/motor is hitting housing.	4. Replace or straighten pump/motor housing.
Pump motor does not run.	1. Loose wiring.	1. Tighten connections.
	2. Thermostat defective.	2. Replace thermostat.

# APPENDIX A-I, PARTS LIST



## A. Parts List

BLN #	Part #	Qty.	UM	Description
1	20916	1	EA	HEAT EXCHANGER AND MOTOR ASSEMBLY
2	14859	1	EA	CAUTION LABEL
4	12793	50	FT	HOSE 3/4" I.D. HYD. LOW PRESSURE
5		1	EA	OIL COOLER MOUNTING BRACKET
6		6	EA	WASHER FLAT USS 3/8"
7		2	EA	WASHER LOCK 3/8"
8		2	EA	NUT HEX 3/8-16
9		2	EA	BOLT CARRIAGE 3/8-16X1"
10		6	EA	NUT KEP LOCK 3/8-16
11		6	EA	BOLT HHCS 3/8-16X1"
12		4	EA	NUT KEP LOCK #10-24
13		4	EA	BOLT PHIL PAN HD #10-24X1/2"
14	890-6929-001	1	EA	THERMOSTAT FOR OIL COOLER
15		4	EA	BOLT CARRIAGE 1/4-20X3/4"
16	19337	1	EA	ELBOW (90) 3/4"NPT TO 1" HOSE BARB
17	1890	1	EA	MOTOR AND PUMP ASSEMBLY
18	3269	1	EA	NIPPLE CLOSE SCH80 3/4"x1 3/8" LONG
19	19119	1	EA	FILTER HEAD W/ SIGHT GAUGE 10 MICRON FILTER
20	17102	1	EA	FITTING 3/4" MALE NPTx12JIC MALE 90° ELBOW
21	12785	1	EA	FITTING 3/4" HOSE BARBx12JIC FEMALE
22		4	EA	NUT KEP LOCK 1/4-20
27	12783	2	EA	CONN. STRAIGHT 3/4" MALE NPTx3/4" PUSHLOCK HOSE BARB
28	20924	1	EA	OIL COOLER SERIAL# TAG
30	19339	1	EA	CLAMP HOSE 1 1/2" T-BAR TYPE
31	19340	1	EA	HOSE 1" SUCTION X 8'-0" LONG(U416 1" ID SEA 100R4)
33	12562	1	EA	GROMMET FOR THERMOSTAT HOLE
34	20982	1	EA	DUCT SCREWING FLANGE
	22130-001	1	EA	GROMMET 1.020-1.109 (DISCHARGE)
	22130-002	1	EA	GROMMET 1.500-1.624 (SUCTION)
	15769	6	EA	CABLE TIE (14" 120# TENSILE, NOT SHOWN)
Replacement	13412	1	EA	Oil Pump (Pump Only)
Replacement	13411	1	EA	Motor For Oil Pump (Motor Only)
Replacement	15527	1	EA	Coupling For Oil Cooler, Between Motor & Pump
Replacement	20917	1	EA	Motor For Heat Exchanger (Motor Only)
Replacement	1953	1	EA	Oil Filter Replacement (10 Micron Filter Std)

# APPENDIX A-2, PARTS DIAGRAM

# A

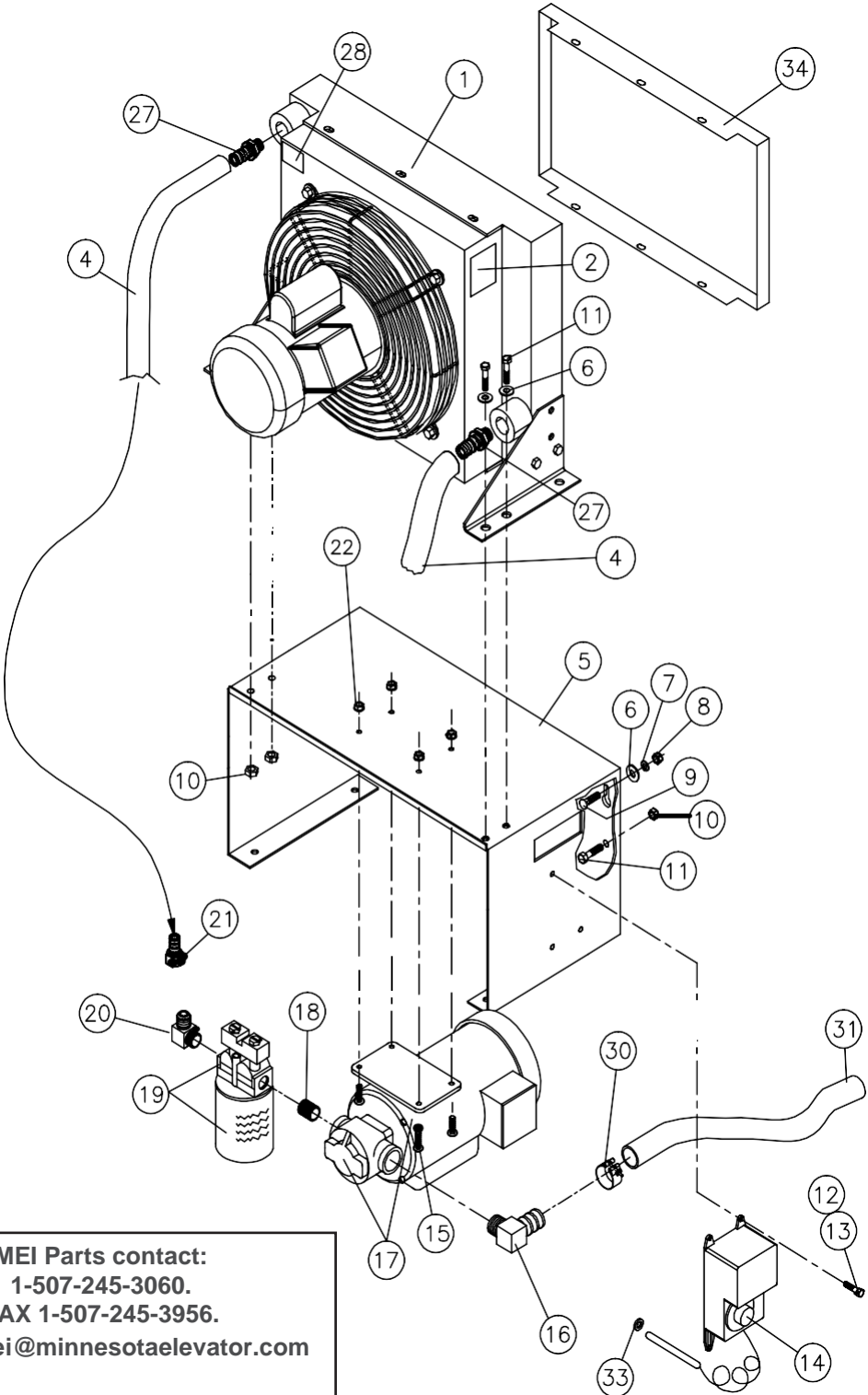

**MEI Parts contact:**  
1-507-245-3060.  
FAX 1-507-245-3956.  
e-mail [mei@minnesotaelevator.com](mailto:mei@minnesotaelevator.com)

Have unit serial number available (located on heat exchanger upper left corner).

## APPENDIX B, WARRANTY

---

# B

### EQUIPMENT WARRANTY

Go to our website [meiusa.com](http://meiusa.com) under contacts, terms and conditions.

- Manufacturing – Parts
- Failure to follow the installation instructions, or utilizing materials not supplied by MEI will void the warranty.